

M. NECKERMANN.

Taper-Turning Attachments to Lathes.

No. 143,296.

Patented September 30, 1873.

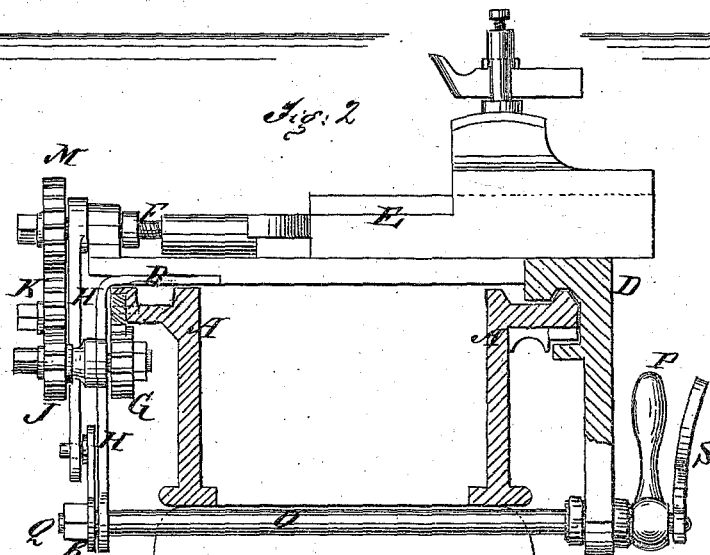
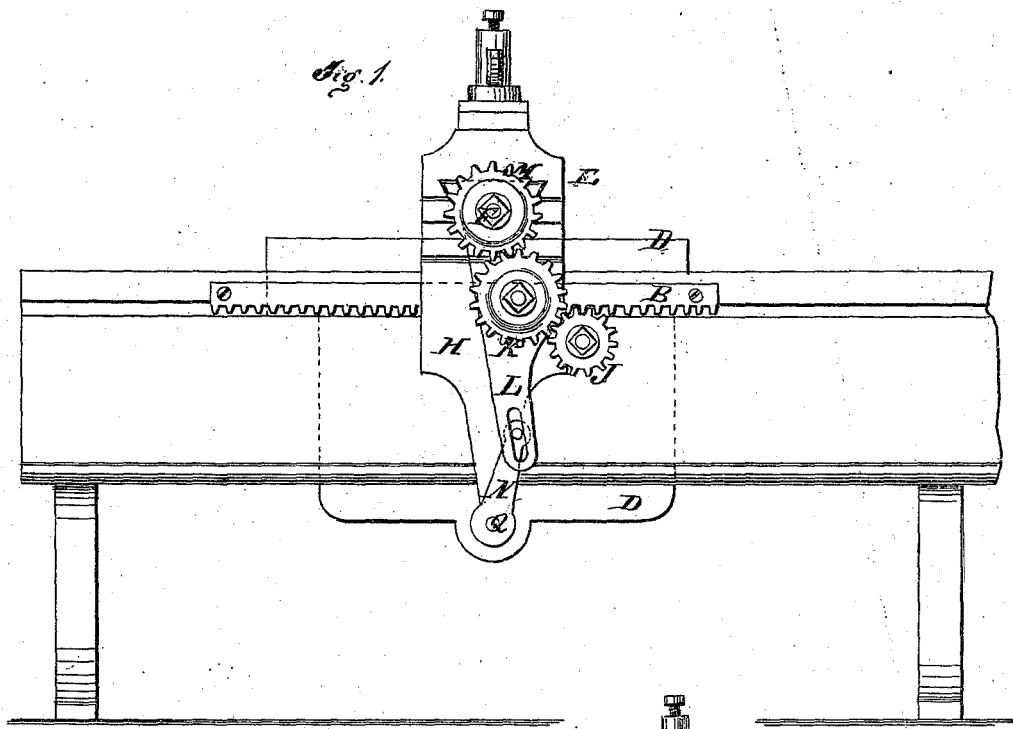

Witnesses.

Chas. Nida.
Belquiere

Inventor.

M. Neckermann

Per

Munn

Attorneys.

UNITED STATES PATENT OFFICE.

MICHAEL NECKERMANN, OF PITTSBURG, PENNSYLVANIA.

IMPROVEMENT IN TAPER-TURNING ATTACHMENTS TO LATHES.

Specification forming part of Letters Patent No. **143,296**, dated September 30, 1873; application filed May 10, 1873.

To all whom it may concern:

Be it known that I, MICHAEL NECKERMANN, of Pittsburg, in the county of Allegheny and State of Pennsylvania, have invented a new and Improved Tapering Attachment to Turning-Lathes, of which the following is a specification:

My invention consists of a toothed rack on a lathe-frame, and a system of gears on the tool-slide, which moves lengthwise of the lathe, combined with the screw which works the tool-slide crosswise in such manner that the tool is fed crosswise of the lathe at the same time that it is fed lengthwise, so as to turn tapers. The wheels are graduated and the supports contrived so that, by the use of interchangeable wheels of different sizes and numbers of teeth, tapers of various predetermined angles can be produced, and they can be turned either way—that is to say, from the large to the small end, or vice versa.

Figure 1 is a side elevation of my improved lathe, and Fig. 2 is a transverse section.

Similar letters of reference indicate corresponding parts.

A represents the shears or frame of the lathe; B, the toothed rack thereon, preferably at the back side; D, the tool-slide, which moves in the lengthwise direction; E, the cross-slide; and F, the screw for moving the latter crosswise or at right angles with the axis of the lathe-centers. G is a pinion on a short shaft mounted on the vertical plate H, hanging down from slide D, and gearing with the rack B. On the outer end of this shaft is a pinion, J, which gears with an idle-wheel, K, on a stud projecting from the bar L, which hangs on the feed-screw F, on which it is fitted so that it can swing toward and from pinion J. This idle-wheel K gears with a pinion, M, on the feed-screw, so that, as the slide D moves along the lathe, the pinion G is turned by the toothed rack, and motion is imparted to the feed-screw F, so as to work the tool crosswise very slowly at the same time that it is moved in the other direction. The object of having the bar L swing is to

allow of the employment of idle-wheels of different sizes to vary the speed of the screw F, and thus make different tapers; also, to throw the feed-screw out of gear when it is not required to taper the work. It is worked by the crank N, shaft O, and lever P, arranged to shift it from the front side of the lathe. The shaft is hollow, and a rod, Q, with a nut or head, R, on one end, and a handled clamp-nut, S, on the other, runs through it, so that it is fastened to hold the wheel K in or out of gear with the pinion J by screwing up the clamp-nut. These wheels are proportioned in the numbers of their teeth to the feed-screw F; also, the screw (not shown) which moves the slide D in respect to their pitch to produce the taper required, a different idle-wheel for each different taper required being used.

By the use of an additional idle-wheel, the application of which will be readily understood, the taper will be the reverse of that produced by one idle-wheel, because it will reverse the motion of feed-screw F. This will be very useful in turning connecting-rods of steam-engines, and other rods or shafts that are made large in the middle and tapering each way. The attachment will be very useful in fitting piston-rods with tapered ends in tapered holes in the cross-head, as the holes and the rods can be turned on the same taper, and thus be made to fit exactly.

Having thus described my invention, I claim as new and desire to secure by Letters Patent—

1. The combination, with the feed-screw of the cross-slide and the shears of the lathe, of a toothed bar, B, and intermediate wheels connecting the feed-screw and the toothed bar, substantially in the manner described.

2. The combination of the swinging bar L, crank N, shaft O, clamping-rod Q, and clamp-nuts, substantially as specified.

MICHAEL NECKERMANN.

Witnesses:

T. B. MOSHER,
ALEX. F. ROBERTS.